

DJSF1352-RN 导轨式直流电能表
DJSF1352-RN rail-mounted DC power meter

安装使用说明书 V1.8
Installation and Operation Instruction V1.8

安科瑞电气股份有限公司

ACREL CO., Ltd.

2019.01

申 明

版权所有，未经本公司之书面许可，此手册中任何段落、章节内容均不得被摘抄、拷贝或以任何形式复制、传播，否则一切后果由违者自负。

本公司保留一切法律权利。

本公司保留对本手册所描述之产品规格进行修改的权利，恕不另行通知。订货前，请垂询当地代理商以获悉本产品的最新规格。

DECLARATION

No part of this publication may be reproduced, stored in a retrieval system, or transmitted in any form by any means, electronic, mechanical photocopying, recording, or otherwise without prior permission of Acrel. All rights reserved.

This company reserve power of revision of product specification described in this manual, without notice. Before ordering, please consult local agent for the latest specification of product.

目录

CONTENTS

目录.....	2
1 概述 Overview.....	1
2 产品规格 Product specification.....	1
3 技术参数 Technical parameters.....	2
4 安装指南 Installation guide.....	3
4.1 外形及安装尺寸.....	3
4.1.1 产品安装 Product installation.....	3
4.2 端子及接线 Terminals and wiring.....	4
4.3 注意事项 Precautions.....	6
4.3.1 电压信号输入 Voltage input.....	6
4.3.2 电流信号输入 Current input.....	6
4.3.3 通讯接口接线 Communication interface wiring.....	6
5 使用指南 Operation guide.....	6
5.1 按键 Key.....	6
5.2 仪表开机瞬间显示为仪表版本信息.....	7
5.3 测量参数 Measurement parameters.....	7
5.3.1 电力参数 Electrical parameters.....	7
5.3.2 费率电度 Multi-rate.....	9
6 菜单符号及意义 Menu symbol and meaning.....	10
6.1 开关量输出设置 Switch output setting.....	12
6.2 编程流程 Programming process.....	14
6.3 功能设置与使用 Function setting and use.....	14
6.3.1 倍率更改设置 Magnification change settings.....	14
6.3.2 通讯功能及参数设置 Communication function and parameter setting.....	15
6.3.3 报警功能及参数设置 Alarm function and parameter setting.....	15
7 通讯指南 Communication Guide.....	15
7.1 概述 Overview.....	15
7.2 DLT645 规约 DLT645 protocol.....	16
7.3 Modbus 协议 Modbus protocol.....	18
7.3.1 数据帧 Data frame format.....	18
7.3.2 地址(Address)域 Address domain.....	18
7.3.3 功能(Function)域 Function domain.....	18
7.3.4 数据(Data)域 Data domain.....	19
7.3.5 错误校验(Check)域 Error check domain.....	19
7.3.6 错误校验的方法 Error check method.....	19
7.4 Modbus 通讯说明 MODBUS communication description.....	20
7.4.1 通信地址表(Word)Communication address table(Word).....	20
7.4.2 说明:.....	27
7.5 通讯应用 Communication application.....	27

1 概述 Overview

DJSF1352-RN 导轨式直流电能表带有双路直流输入，主要针对电信基站、直流充电桩、太阳能光伏等应用场合而设计，该系列仪表可测量直流系统中的电压、电流、功率以及正反向电能等。在实际使用现场，即可计量总电能，又可计量规定时间段内的电能。检测的结果既可用于本地显示，又能与工控设备、计算机连接，组成测控系统。

仪表可具有红外通讯接口和RS-485通讯接口，同时支持Modbus-RTU协议和DLT645-97(07)协议；可带继电器报警输出和开关量输入功能；根据不同要求，通过仪表面板按键，对变比、报警、通讯进行设置；具有开关量事件记录（Modbus协议）、编程和事件设置记录（645协议）、数据瞬时和定时冻结功能（645协议）、电压电流功率最大值、最小值记录功能。

DJSF1352-RN rail-mounted DC power meter with double DC input channels, designed for telecommunications base stations, DC charging piles, solar photovoltaic and other applications, this series of meters can measure the voltage, current, power and forward and reverse energy and so on in the DC system. The actual use of the site, you can measure the total power, but also measure the energy within a specified period of time. The test results can be used for local display, but also with industrial control equipment, computers to form a measurement and control system.

The meter can have infrared communication interface and RS-485 communication interface, and supports Modbus-RTU protocol and DLT645-97 (07) protocol at the same time. The meter can have relay alarm output and digital input function; You can set the ratio, alarm, and communication through the meter panel keys according to different requirements. The meter can have event recording of switch (Modbus protocol), programming and event setting records (645 protocol), instantaneous and timing freeze function of data (645 protocol), maximum and minimum value recording function of voltage and current power.

2 产品规格 Product specification

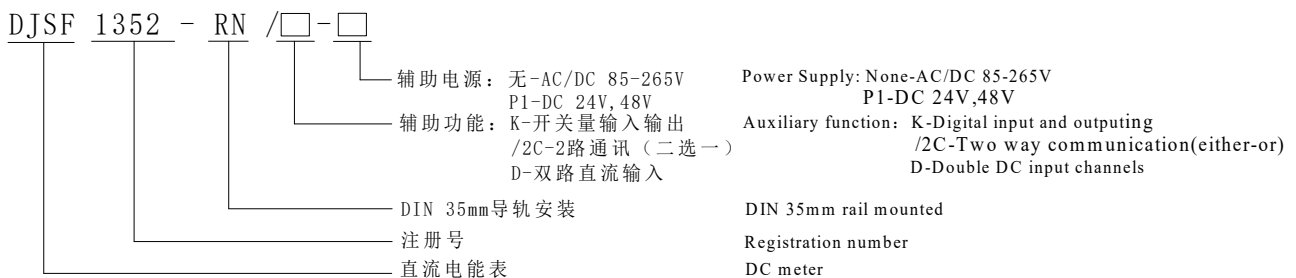

3 技术参数 Technical parameters

技术参数 Technical parameters		指标 Index		
输入 Input	标称值 Nominal value	电压输入范围 Voltage input range	电流输入 Current input	
		DC 0-1000V 参见实物接线图 DC 0-1000V See the physical wiring diagram	分流器: 0-75mV; 霍尔传感器: 0-20mA、4-20mA、0-5V, 0-10V 等 Shunt: 0-75mV; Hall sensor: 0-20mA、4-20mA、0-5V, 0-10V and so on.	
	过载 Overload	1.2 倍可持续正常工作, 2 倍持续 1 秒 1.2 times rated (continuous); 2 times rated/1 second;		
功耗 Power consumption	电压: $\leq 0.2VA$, 电流 $\leq 0.1VA$ Voltage: $\leq 0.2VA$, current $\leq 0.1VA$			
精度等级 Accuracy class		1 级 Class 1		
功能 Function	显示 Display	8 位段码式液晶屏 (LCD) 8-bit segment LCD screen (LCD)		
	通讯接口 Communication Interface	RS485, 红外 RS485, infrared		
	通讯协议 Communication protocol	Modbus-RTU, DL/T 645-2007		
	开关量 Switch	开关量输出 Switch output	2 路继电器输出, 2A/30VDC 或 2A/250VAC 2 Relay outputs, 2A/30VDC or 2A/250VAC	
		开关量输入 Switch input	2 路干接点输入 2 dry contact inputs	
脉冲输出 Pulse output	一路秒脉冲输出, 一路电能脉冲输出 A second pulse output, a energy pulse output 见仪表菜单设置中 SYS->PLUS 中显示, 例: 显示 100, 即为 100imp/kWH See the SYS->PLUS display in the meter menu settings. For example: The meter displays 100, which is 100imp/kWH			
工作电源 Power Supply	电压范围 Voltage range	AC/DC 85-265V 或 DC24V($\pm 10\%$)或 DC48V($\pm 10\%$) AC/DC 85-265V or DC24V($\pm 10\%$) or DC48V($\pm 10\%$)		
	功耗 Power consumption	$\leq 3W$		
工频耐压 Power frequency withstand voltage		电源//电压输入//电流输入//继电器输出和开关量输入//通讯之间//脉冲输出 3kV/1min 电源、继电器输出、电压信号、电流信号之间 3kV/1min 脉冲输出、通讯、开关量输入之间 2kV/1min Power supply // Voltage input // Current input // Relay output and switch input // Communication interface // Pulse output 3kV/1min Power supply // Relay output // Voltage input // Current input 3kV/1min Pulse output // Communication interface // Switch input 2kV/1min		

绝缘电阻 Insulation resistance		$\geq 40M \Omega$
平均无障碍工作时间 Average barrier-free working hours		$\geq 50000h$
环境 Environment	温度 Temperature	正常工作温度: $-25^{\circ}C \sim +65^{\circ}C$; 极限工作温度: $-40^{\circ}C \sim +70^{\circ}C$; 贮存温度: $-40^{\circ}C \sim +80^{\circ}C$ Normal operating temperature: $-25^{\circ}C \sim +65^{\circ}C$; Limit working temperature: $-40^{\circ}C \sim +70^{\circ}C$; Storage temperature: $-40^{\circ}C \sim +80^{\circ}C$
	湿度 Humidity	$\leq 93\%RH$, 不结露, 不含腐蚀性气体 $\leq 93\%RH$, no condensation, no corrosive gas
	海拔 Altitude	$\leq 2500m$

脉冲常数: Pulse constant:

最大功率 \leq Maximum power	999.9W	10000	imp/kWh
	9.999kW	1000	imp/kWh
	99.99kW	100	imp/kWh
	999.9kW	10	imp/kWh
	9999kW	1	imp/kWh

最大功率=额定电压*电压比值*电流比值*1.2

Maximum power = rated voltage * voltage ratio * current ratio * 1.2

4 安装指南 Installation guide

4.1 外形及安装尺寸

Shape and installation dimensions

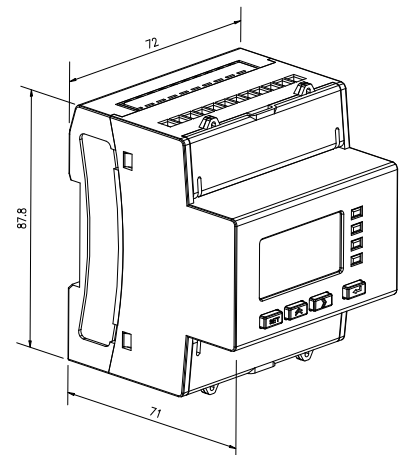
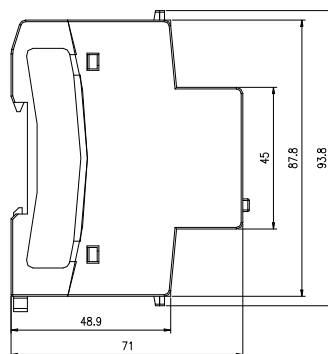

4.1.2 产品安装 Product installation

采用标准的 DIN35mm 导轨式安装

The meter is designed by standard DIN35mm rail mounted.

4.2 端子及接线 Terminals and wiring

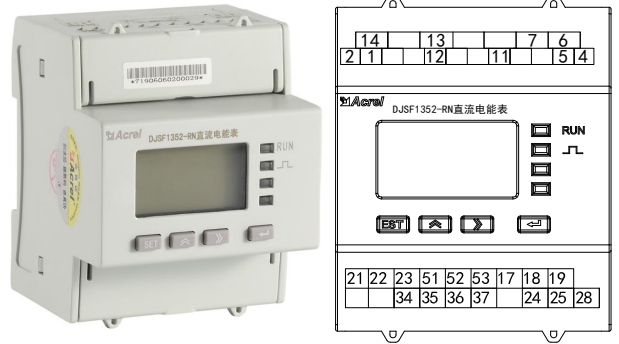
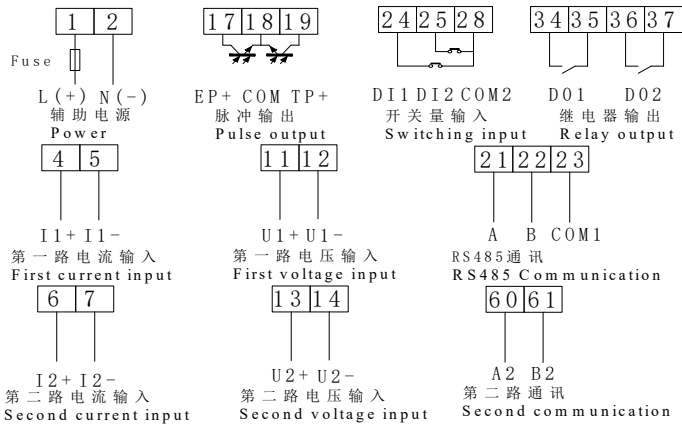

注：第二路直流输入以及DI、DO功能均为选配功能。

Note: The second DC input channel and DI and DO functions are optional.

当电流输入方式为分流器输入时：

When the current input mode is current shunt input:

三线制接法 Three-wire connection

正极电流分流器输入

负极电流分流器输入

Current shunt connected to the positive

Current shunt connected to the negative

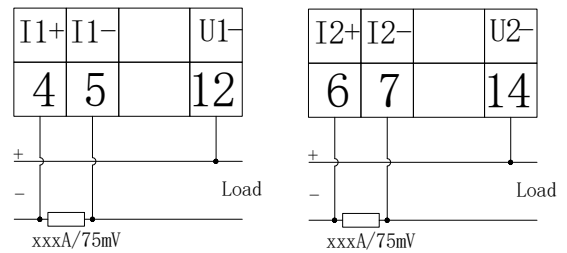
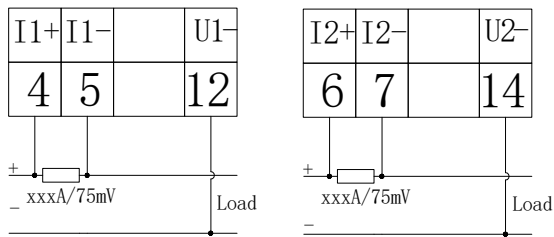

第一路直流输入 First DC input channel

第二路直流输入 Second DC input channel

四线制接法 Four-wire connection

正极电流分流器输入

负极电流分流器输入

Current shunt connected to the positive

Current shunt connected to the negative

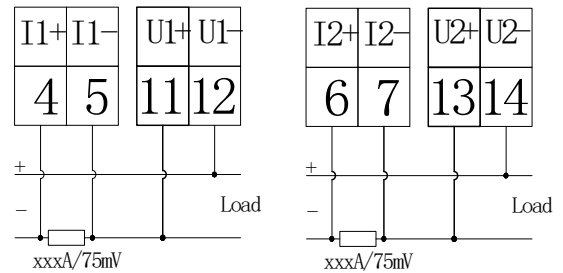
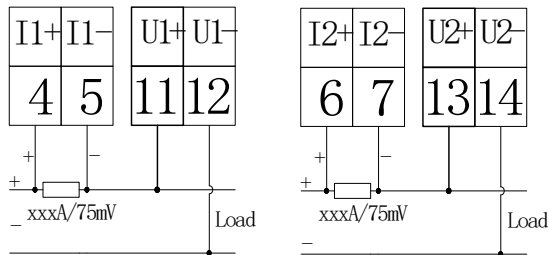

当电流输入方式为霍尔传感器输入时：

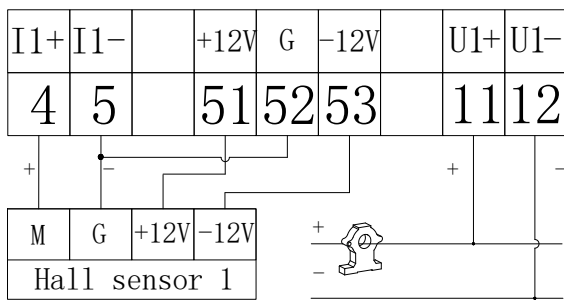

第一路直流输入 First DC input channel

- 注：1. 负极电流分流器输入时，需在仪表菜单将 **negt** 选项设置为on，详见第6节菜单编程界面。
2. 当两路电流输入均采用霍尔电流传感器输入时，第二路霍尔电流传感器的电源不能使用电表内置电源，需外配电源模块。
3. 电流采用分流器输入，四线制接法所测量的电压值会有额外千分之一左右的误差。
4. 电流信号线推荐使用0.75mm²或1mm²屏蔽双绞线，且屏蔽层需要接大地。

When the current input mode is Hall sensor input:

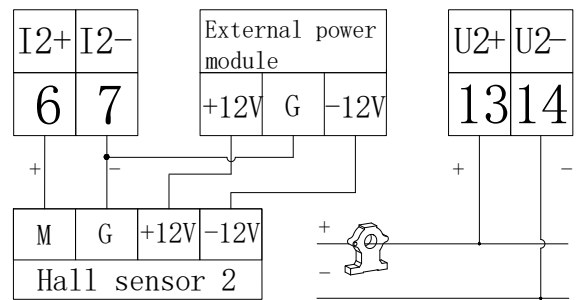

第二路直流输入 Second DC input channel

- Note: 1. When current shunt is connected to the negative, set the **negt** option to on in the meter menu, see section 6 menu programming interface for details.
2. When the two current inputs are input by the Hall current sensor, the power supply of the second Hall current sensor cannot be used with the built-in power supply of the meter, and the power module needs to be externally connected.
3. When the current is input by the shunt, the voltage value measured by the four-wire method has an error of about one thousandth.
4. It is recommended to use a 0.75mm² or 1mm² shielded twisted pair for the current signal line, and the shield layer needs to be connected to the ground.

4.3 注意事项Precautions

4.3.1 电压信号输入Voltage input

输入电压不得高于产品的额定输入电压的120%，在电压输入端须安装1A 保险丝。

The input voltage must not exceed 120% of the rated input voltage of the product. A 1A fuse must be installed on the voltage input.

4.3.2 电流信号输入Current input

电流输入应使用外部分流器或霍尔电流传感器。

An external shunt or Hall current sensor should be used for current input.

4.3.3 通讯接口接线Communication interface wiring

该仪表提供异步半双工 RS485 通讯接口，采用 MODBUS-RTU 协议，各种数据信息均可在通讯线路上传送。理论上在一条线路上可以同时连接多达 128 个仪表，每个仪表均可设定其通讯地址（Addr）、通讯速率（baud）也可通过设置选择。

The meter provides asynchronous half-duplex RS485 communication interface using MODBUS-RTU protocol, a variety of data information can be transmitted on the communication line. Theoretically, up to 128 meters can be connected simultaneously on a single line. Each meter can be set with its address (Addr), baud rate, or setting selection.

通讯连接建议使用三芯屏蔽线，每芯截面不小于 0.5mm^2 ，分别接 A、B，屏蔽层接大地，布线时应使通讯线远离强电电缆或其他强电场环境。



The communication connection is recommended to use three-core shielded cable, Cross-sectional area of each core is not less than 0.5mm^2 , is connected to A、B respectively, shielding layer is connected to the earth. The wiring should be kept away from strong cables or other strong electric field environment.



建议起始端和最末端仪表的 A、B 之间均加匹配电阻，阻值范围为 $20\Omega \sim 10\text{k}\Omega$ 。

It is recommended to add matching resistors between A and B of the meters at the beginning and end. The resistance range is 20Ω to $10\text{k}\Omega$.

5 使用指南 Operation guide

5.1 按键 Key

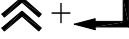
Set	<p>测量模式下，按该键进入编程模式，仪表提示输入密码 PASS，输入正确密码后，可对仪表进行编程设置；编程模式下，用于返回上一级菜单</p> <p>In the measurement mode, press this key to enter the programming mode. The meter prompts you to enter the password PASS. After you enter the correct password, you can program the instrument; in the programming mode, it returns to the previous menu.</p>
	<p>测量模式下，用于切换显示项目，查看各项电量，具体见显示菜单；编程模式下，用于切换同级菜单或个位数的减小。</p> <p>In the measurement mode, it is used to switch the display item and view the electrical parameters, see the display menu for details;</p> <p>In the programming mode, it is used to switch the menu of the same level or reduce the number of ones place.</p>
	<p>测量模式下，可查看相关参数，查看各项电量，具体见显示菜单；编程模式下，用于切换同级菜单或个位数的增加。</p> <p>In the measurement mode, it is used to switch the display item and view the electrical parameters, see the display menu for details;</p> <p>In the programming mode, it is used to switch the menu of the same level or add the number of ones place.</p>

	编程模式下，用于菜单项目的选择确认和参数的修改确认。 In the programming mode, it is used to confirm the selection of menu items and modify the parameters.
	编程模式下，该组合键用于百位数的减小 In the programming mode, this key combination is used to reduce the number of hundreds place.
	编程模式下，该组合键用于百位数的增加 In the programming mode, this key combination is used to add the number of hundreds place.

5.2 仪表开机瞬间显示为仪表版本信息

Meter displays the version information for the meter instantly when starts up.

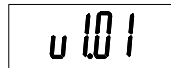

5.3 测量参数 Measurement parameters

5.3.1 电力参数 Electrical parameters

上、右键循环切换显示 如下图所示：按上、右键可如下图切换显示其它界面：电流 ↔ 电压 → 功率 ↔ 当前正向有功电能 ↔ 历史反向有功电能 ↔ 当前日期时间 ↔ 温度。

Press the up and right key to switch display circularly, as is shown in the following figure: Press the up or right key to switch display the other interface as follows: Current ↔ Voltage → Power ↔ Current positive active energy ↔ History reverse active energy ↔ Current date time ↔ Temperature.

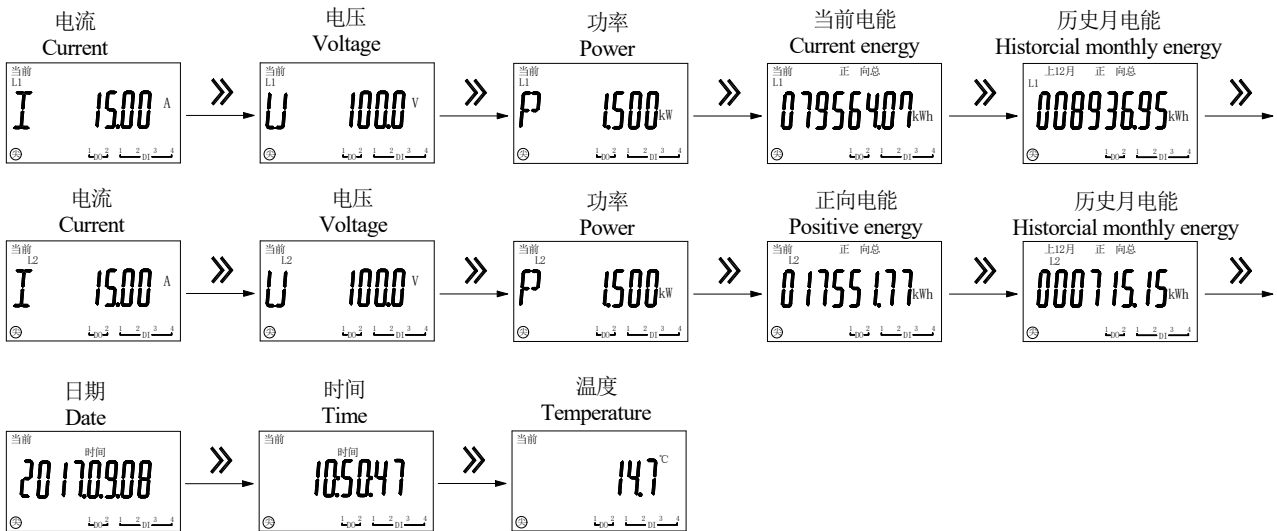

注：1、L1、L2 分别表示第一路、第二路直流输入，
当未选配第二路直流输入时，L2 参数界面不显示；
2、当功率为负值时，屏幕闪烁；
3、费率电度只有在仪表带此功能时显示。

Note: 1. L1 and L2 represent the first and second DC input respectively. When the second DC input is not selected, the L2 parameter interface is not displayed.
2. When the power is negative, the screen flickers;
3. Multi-rate energy is only displayed when the instrument with this function.

说明:

01: 从机地址

03: 功能码

04: 十六进制, 十进制为 4, 表示后面有 4 个字节的数
Hexadecimal, decimal is 4, indicates that the following 4 bytes of data

5a 50: 循环冗余校验码

处理如下: 03 b2(16 进制) = 946 (10 进制电流数据)

00 00(16 进制) = 0 (10 进制小数点数据)

计算: $946 \times 10^{-3} = 0.946$; 单位: 安培 (A)

则仪表显示:

I=0.946

读电压表数据与读电流表类似, 但起始地址为 00H,

查询帧: 01 03 00 00 00 02 c4 0b

读其它信息的查询帧与此格式相同, 各信息地址见通讯参量地址表。

注: 电压、电流、功率的有效数据与指数位均为有符号数据, 若一数读为“FFFF”, 则表示该数据为“-1”

Description:

01: Slave address

03: Function code

04: Hexadecimal, decimal is 4, indicates that the following 4 bytes of data

5a 50: Cyclic Redundancy Check Codes

The processing is as follows:

03 b2 (hexadecimal) = 946 (decimal current data)

00 00 (hexadecimal) = 0 (decimal data)

Calculation: $946 \times 10^{-3} = 0.946$; Unit: Ampere (A)

The meter displays:

I=0.946

Reading voltage data is similar to reading current, but the starting address is 00H, query frame: 01 03 00 00 00 02 c4 0b.

The query frame for reading other information is the same as this format, and each information address is in the communication parameter address table.

Note: The valid data and exponent bits of voltage, current, and power are both signed data. If a number is read as “FFFF”, it means the data is “-1”.

总部：安科瑞电气股份有限公司
地址：上海市嘉定区马东工业园育绿路 253 号
电话：021-69158300 69158301 69158302
传真：021-69158303
服务热线：800-820-6632
网址：www.acrel.cn
邮箱：ACREL001@vip.163.com
邮编：201801
Address: Yulv Road 253, Madong Industrial Park, Jiading, Shanghai
Fax: (86)21-69158303
Service hotline: 800-820-6632
Website: www.acrel.cn
E-mail: ACREL001@vip.163.com
P.C.: 201801

生产基地：江苏安科瑞电器制造有限公司
地址：江阴市南闸街道东盟路 5 号
电话（传真）：（86）0510-86179970
邮编：214405
邮箱：JY-ACREL001@vip.163.com
Production base: Jiangsu Acrel Electric Appliances Manufacturing Co., Ltd,
Address: Dongmeng Road 5, Nanzha Street, Jiangyin City
Tel./fax: (86)0510-86179970
P.C.: 214405
E-mail: JY-ACREL001@vip.163.com

更改记录：

V1.1: 增加电表实际端子位置图示

V1.2: 增加分流器接负端接线图，同时在菜单编程界面增加 ~~0E9E~~ 设置选项

V1.3: 1.更改电流霍尔部分接线图，第二路霍尔输入不能用电表内置电源，需外配；
2. 菜单新增电压、电流零点屏蔽功能。

V1.4: 增加四线制接法

V1.5: 增加电流输入信号线推荐使用 0.75mm² 或 1mm² 屏蔽双绞线，屏蔽层接大地

V1.6: 1.增加电压、电流输入的二次弱信号线推荐使用 0.75mm² 或 1mm² 屏蔽双绞线，且屏蔽层需要接大地
2.修改仪表第一个按键由 ESC 改为 SET,修改端子号。

V1.7.: 1.增加继电器一和继电器二的通讯地址
2.修改技术参数的环境温度和操作界面错误的数值
3.辅助功能 K/2C 改为二选一
4.增加通讯菜单